

# RT-11 and RT-11N

## Districts Schedule

### 1 INTENT AND OVERVIEW

#### 1.1 Intent

The intent of this schedule is to allow a variety of housing options by encouraging development of multiple small single detached houses and duplexes on larger lots and assembled sites, while continuing to permit lower intensity development on smaller sites. Siting and massing are intended to be compatible with, but not the same as, pre-existing single detached development. Laneway houses, secondary suites, and lock-off units are permitted, within limits, to provide flexible housing choices. Retention of character buildings is encouraged. In the RT-11N district, acoustic regulations in [Section 10](#) of this by-law apply to dwelling units close to arterial streets.

Without limitation, applicable Council policies and guidelines for consideration include the [RT-11 and RT-11N Guidelines](#).

#### 1.2 Overview

The table below provides an overview of the outright and conditional approval uses in the RT-11 and RT-11N districts, categorized by the minimum site area required, where applicable. Applicable density, form and placement regulations in section [3](#) of this schedule are cross-referenced in the third column.

Minimum Site Area	Use	Density, Form and Placement Regulations
511 m <sup>2</sup>	Duplex or Duplex with Secondary Suite on a site with more than 1 principal building	<a href="#">3.1</a>
	Single Detached House or Single Detached House with Secondary Suite on a site with more than 1 principal building	<a href="#">3.1</a>
334 m <sup>2</sup>	Infill Single Detached House or Infill Duplex	<a href="#">3.1</a>
	Duplex with Secondary Suite	<a href="#">3.1</a>
	Multiple Conversion Dwelling, containing 3 dwelling units	<a href="#">3.1</a>
303 m <sup>2</sup>	Duplex	<a href="#">3.1</a>
	Multiple Conversion Dwelling, containing 2 dwelling units	<a href="#">3.1</a>
--	Other uses in section <a href="#">2.1</a> of this schedule	<a href="#">3.1</a>

<b>Minimum Site Area</b>	<b>Use</b>	<b>Density, Form and Placement Regulations</b>
Regulated by the <b>R1-1 District Schedule</b>	Single Detached House or Single Detached House with Secondary Suite	Regulated by the <b>R1-1 District Schedule</b>
--	Laneway House	Regulated by the <b>R1-1 District Schedule</b>

## **2 USE REGULATIONS**

### **2.1 Outright and Conditional Approval Uses**

All outright and conditional approval uses are subject to all other provisions of this by-law, including [Section 2](#), [Section 10](#) and [Section 11](#), and compliance with the regulations of this schedule including section [2.2](#).

The uses identified in the table below as outright approval uses are permitted in these districts and will be issued a permit.

The uses identified in the table below as conditional approval uses may be approved in these districts by the Director of Planning, with or without conditions, if the Director of Planning considers:

- (a) the intent of this schedule and all applicable Council policies and guidelines; and
- (b) the submission of any advisory group, property owner or tenant.

Uses are listed under their general land use category. Applicable use-specific regulations in section [2.2](#) of this schedule are cross-referenced in the third column. Cross-references to applicable use-specific regulations are provided for information purposes only and do not form part of this by-law.

<b>Use</b>	<b>Approval</b>	<b>Use-Specific Regulations</b>
<b>Agricultural Uses</b>		
Urban Farm - Class A	Conditional	
<b>Cultural and Recreational Uses</b>		
Club	Conditional	
Community Centre or Neighbourhood House	Conditional	
Library, in combination with Community Centre	Conditional	
Park or Playground	Conditional	

<b>Use</b>	<b>Approval</b>	<b>Use-Specific Regulations</b>
<b>Dwelling Uses</b>		
Duplex	Outright	
Duplex with Secondary Suite	Conditional	<a href="#">2.2.1</a>
Duplex, on a site with more than 1 principal building	Conditional	<a href="#">2.2.2</a>
Duplex with Secondary Suite, on a site with more than 1 principal building	Conditional	<a href="#">2.2.2</a>
Infill Duplex, in combination with the retention of a building existing on the site prior to January 1, 1940	Conditional	
Infill Single Detached House	Conditional	<a href="#">2.2.3</a>
Laneway House	Conditional	<a href="#">2.2.4</a>
Mixed-Use Residential Building	Conditional	<a href="#">2.2.5</a>
Multiple Conversion Dwelling, containing 2 dwelling units	Outright	<a href="#">2.2.6</a>
Multiple Conversion Dwelling, not permitted as an outright approval use and resulting from the conversion of a building existing on the site as of May 15, 2013	Conditional	<a href="#">2.2.7</a>
Principal Dwelling Unit with a Lock-Off Unit	Conditional	<a href="#">2.2.8</a>
Seniors Supportive or Independent Living Housing	Conditional	
Single Detached House	Outright	<a href="#">2.2.9</a>
Single Detached House with Secondary Suite	Conditional	<a href="#">2.2.9</a>
Single Detached House, on a site with more than 1 principal building	Conditional	<a href="#">2.2.2</a>
Single Detached House with Secondary Suite, on a site with more than 1 principal building	Conditional	<a href="#">2.2.2</a>
<b>Institutional Uses</b>		
Ambulance Station	Conditional	
Child Day Care Facility	Conditional	
Church	Conditional	
Community Care or Assisted Living Facility - Class A	Outright	<a href="#">2.2.10</a>
Community Care or Assisted Living Facility - Class B	Conditional	
Group Residence	Conditional	
Hospital	Conditional	
Public Authority Use, essential in these districts	Conditional	
School - Elementary or Secondary	Conditional	
Social Service Centre	Conditional	
<b>Office Uses</b>		
Temporary Sales Office	Conditional	

<b>Use</b>	<b>Approval</b>	<b>Use-Specific Regulations</b>
<b>Retail Uses</b>		
Farmers' Market	Conditional	<a href="#">2.2.11</a>
Neighbourhood Grocery Store	Conditional	
Public Bike Share	Conditional	
Shared E-Scooter System	Conditional	
<b>Service Uses</b>		
Bed and Breakfast Accommodation	Conditional	
Short Term Rental Accommodation	Conditional	
<b>Utility and Communication Uses</b>		
Public Utility	Conditional	
<b>uncategorized</b>		
Accessory Buildings, customarily ancillary to any use listed in this section <a href="#">2.1</a>	Outright	<a href="#">2.2.12</a> , <a href="#">2.2.13</a>
Accessory Buildings, customarily ancillary to any use listed in this section <a href="#">2.1</a> and not permitted as an outright approval use	Conditional	
Accessory Uses, customarily ancillary to any outright approval use listed in this section <a href="#">2.1</a>	Outright	<a href="#">2.2.14</a>
Accessory Uses, customarily ancillary to any conditional approval use listed in this section <a href="#">2.1</a>	Conditional	
Deposition or extraction of material, which alters the configuration of the land	Conditional	

## **2.2 Use-Specific Regulations**

2.2.1 Duplex with secondary suite must have no more than 1 secondary suite for each dwelling unit.

2.2.2 The Director of Planning may permit:

(a) 2 principal buildings on a site with a minimum site area of 334 m<sup>2</sup> if:

(i) the site meets at least 1 of the following criteria:

(A) the rear or side property line of the site abuts a park or school site, with or without the intervention of a lane,

(B) the site is a corner site, or

(C) the site is double fronting,

(ii) on sites other than double fronting sites, 1 of the principal buildings is located within the rear 40% of the ultimate site depth, and that building is a single detached house, and

(iii) the Director of Planning considers the intent of this schedule and all applicable Council policies and guidelines; and

(b) more than 1 principal building on a site with a minimum site area of 511 m<sup>2</sup> if the Director of Planning considers the intent of this schedule and all applicable Council policies and guidelines.

2.2.3 Infill single detached house may be permitted if:

(a) it is in combination with the retention of a building existing on the site prior to January 1, 1940; or

(b) the site meets at least 1 of the following criteria:

(i) the rear or side property line of the site abuts a park or school site, with or without the intervention of a lane,

(ii) the site is a corner site, or

(iii) the site is a double fronting site.

2.2.4 Laneway house must be in combination with a single detached house or single detached house with secondary suite, which is the only principal building on the site. Laneway house is regulated by [Section 11](#) of this by-law and sections [3](#) and [4](#) of this schedule do not apply.

2.2.5 The only non-dwelling use permitted in a mixed-use residential building is neighbourhood grocery store.

2.2.6 Multiple conversion dwelling containing 2 dwelling units is permitted as an outright approval use if:

(a) there are no additions to the building;

(b) no housekeeping or sleeping units are created;

(c) the development complies with sections [3.1.2.7](#), [3.1.2.8](#) and [4.3](#) of this schedule; and

(d) no development permit is issued until the requisite permits required by other by-laws that relate to design, construction and safety of buildings are issuable.

2.2.7 Multiple conversion dwelling that is not permitted as an outright approval use, resulting from the conversion of a building existing on the site as of May 15, 2013, may be permitted as a conditional approval use if:

(a) the Director of Planning considers the quality and liveability of the resulting units, the suitability of the building for conversion in terms of age and size and the impact of the conversion on adjacent properties;

(b) no additions are permitted for buildings constructed on or after January 1, 1940, except additions up to 5 m<sup>2</sup> used as exits;

(c) no housekeeping or sleeping units are created; and

(d) there are no more than 3 dwelling units.

- 2.2.8 Principal dwelling unit with lock-off unit may be permitted only on a site with more than 2 principal buildings and a minimum frontage of 18.3 m, in:
  - (a) an infill single detached house;
  - (b) an infill duplex;
  - (c) a single detached house; or
  - (d) a duplex.
  
- 2.2.9 Single detached house or single detached house with secondary suite, where developed as the only principal building on site, must comply with the **R1-1 District Schedule** and sections 3 and 4 of this schedule do not apply.
  
- 2.2.10 Community care or assisted living facility - class A is subject to the regulations, variations and relaxations that apply to single detached house.
  
- 2.2.11 Farmers' market may be permitted if the Director of Planning considers the appropriateness of the use with respect to compatibility with nearby sites, parking, traffic, noise, hours of operation, size of facility and pedestrian amenity.

2.2.12 Accessory buildings customarily ancillary to any use listed in section 2.1 of this schedule, are permitted as an outright approval use if:

- (a) no accessory building exceeds 3.7 m in height, measured to:
  - (i) the highest point of a flat roof,
  - (ii) the deck line of a mansard roof, or
  - (iii) the mean height between the eaves and the ridge of a gable, hip or gambrel roof,

provided that no portion of an accessory building exceeds 4.6 m in building height;
- (b) all accessory buildings are located:
  - (i) within 7.9 m of the ultimate rear property line,
  - (ii) at least 3.6 m from the ultimate centre line of any rear or flanking lane, and

**Diagram: Building placement for accessory building**

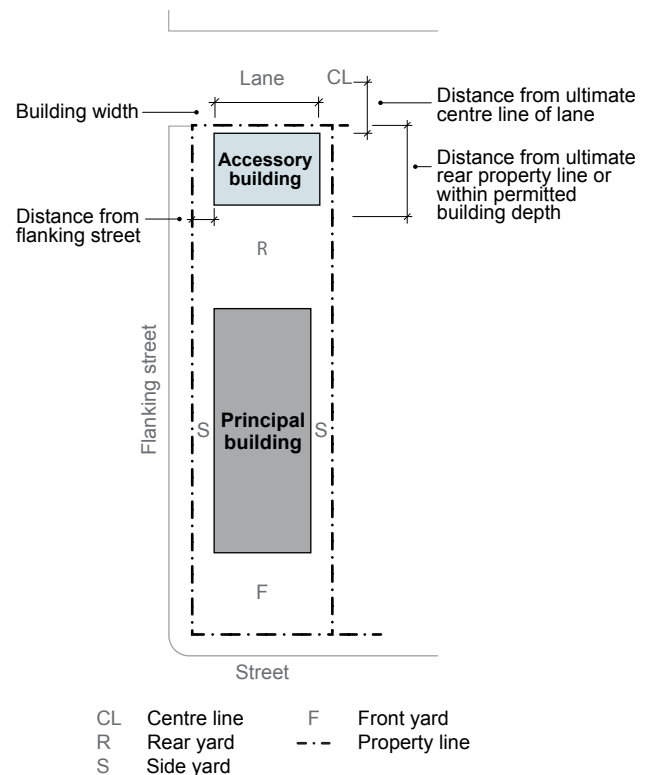

(iii) at least 1.5 m from a flanking street;

(c) the total floor area of all accessory buildings, measured to the extreme outer limits of the building, does not exceed 48 m<sup>2</sup>, except that the total allowable accessory building floor area will be reduced by:

(i) any floor area previously excluded from existing development pursuant to section [4.1.2\(c\)](#) of this schedule, and

(ii) the floor area of a laneway house;

(d) the combined building width for all accessory buildings does not exceed 80% of the width of the site at the rear property line; and

(e) roof decks and decks are not located on an accessory building.

2.2.13 The Director of Planning may vary the site coverage regulations to accommodate an accessory building if:

(a) the Director of Planning is satisfied that adequate off-street parking on any site less than 36.6 m in depth cannot otherwise be accommodated; and

(b) the Director of Planning also considers the impact on neighbouring sites of building height, shadow, open space and landscaping, the intent of this schedule and all applicable Council policies and guidelines.

2.2.14 Accessory parking spaces customarily ancillary to any outright approval use listed in section [2.1](#) of this schedule must comply with the provisions of section [2.2.12\(b\)](#) above.

### 3 DENSITY, FORM AND PLACEMENT REGULATIONS

This section contains density, form and placement regulations organized by use.

#### 3.1 All Uses

Duplex, duplex with secondary suite, multiple conversion dwelling, infill, dwelling uses on a site with more than 1 principal building, uses involving character house retention, and all other uses in these districts, except single detached house and single detached house with secondary suite, as the only principal building on the site, and laneway house, are subject to the following regulations.

##### 3.1.1 Density and Floor Area

3.1.1.1 The maximum floor space ratio is:

- (a) 0.60, for all uses other than duplex or duplex with secondary suite; and
- (b) 0.75 for duplex or duplex with secondary suite on a site with 1 principal building.

3.1.1.2 Despite the maximum floor space ratio in section 3.1.1.1 above, the Director of Planning may increase the permitted floor space ratio to maximum of:

- (a) 0.90 for dwelling uses on sites where buildings existing prior to January 1, 1940 are retained; and
- (b) 0.85 for all other dwelling uses, except for duplex and duplex with secondary suite,

if the Director of Planning considers the intent of this schedule, all applicable Council policies and guidelines, and the submission of any advisory group, property owner or tenant.

3.1.1.3 Despite the maximum floor space ratio in sections 3.1.1.1 and 3.1.1.2 above, on a site:

- (a) with a site area less than 511 m<sup>2</sup>; and
- (b) where a building constructed after January 1, 1940 is not retained,

the floor space ratio allocated to a second principal building or infill single detached house or infill duplex at the rear of the site must not exceed 0.20.

3.1.1.4 On a site with a minimum site area of 511 m<sup>2</sup>, the total number of dwelling units, excluding lock-off units and secondary suites, must not exceed:

- (a) 74 units per hectare on a site with a frontage of 18.3 m or more, except that the number of lock-off units and secondary suites must not exceed the greater of 3 or 45% of the number of dwelling units permitted; and
- (b) 3 dwelling units on a site with a frontage less than 18.3 m,

except that the Director of Planning may permit 1 additional dwelling unit if the Director of Planning considers the intent of this schedule and all applicable Council policies and guidelines.



3.1.1.5 On a site with a site area less than 511 m<sup>2</sup> that:

- (a) abuts a park or school site, with or without the intervention of a lane;
- (b) is a corner site; or
- (c) is a double fronting site,

the total number of dwelling units, excluding lock-off units and secondary suites, must not exceed 3 dwelling units.

### 3.1.2 Building Form and Placement

Regulations	RT-11 and RT-11N
3.1.2.1 Minimum site area for:	
(a) duplex	303 m <sup>2</sup>
(b) multiple conversion dwelling containing 2 units	303 m <sup>2</sup>
(c) duplex with secondary suite	334 m <sup>2</sup>
(d) multiple conversion dwelling containing 3 units	334 m <sup>2</sup>
(e) infill single detached house or infill duplex	334 m <sup>2</sup>
3.1.2.2 Minimum site frontage for all dwelling uses	9.8 m
3.1.2.3 Maximum building height for:	
(a) a building, other than duplex or duplex with secondary suite on a site with 1 principal building:	
(i) in the front 60% of the site depth	10.7 m and 2 storeys
(ii) in the rear 40% of the site depth	7.7 m and 2 storeys
(b) duplex or duplex with secondary suite on a site with 1 principal building in the front 60% of the site depth	10.7 m and 3 storeys
3.1.2.4 Minimum front yard depth:	
(a) on sites with a frontage greater than 18.3 m and more than 1 principal building	4.9 m
(b) on all other sites	the average of the minimum front yard depths of the 2 adjacent sites
3.1.2.5 Minimum side yard width	1.2 m
3.1.2.6 Minimum rear yard depth	0.6 m

Regulations		RT-11 and RT-11N
3.1.2.7	Maximum site coverage	45% of the site area
3.1.2.8	Maximum area of impermeable materials	70% of the site area
3.1.2.9	Maximum building depth for sites with:	40% of the site depth
	(a) 1 principal building	
	(b) 1 principal building with infill	
	(c) 2 principal buildings with the second principal building located at the rear of the site	

**Site Area**

- 3.1.2.10 The Director of Planning may decrease the minimum site area in:
- (a) section 3.1.2.1(a) above for duplex;
  - (b) section 3.1.2.1(c) above for duplex with secondary suite; and
  - (c) section 3.1.2.1(e) above for infill single detached house in combination with the retention of a building existing on the site prior to January 1, 1940,

if the lot was on record in the Land Title Office prior to May 15, 2013 and the Director of Planning considers the quality and liveability of the resulting units, the impact on neighbouring properties, the intent of this schedule, and all applicable Council policies and guidelines.

**Diagram: Yards for principal building**

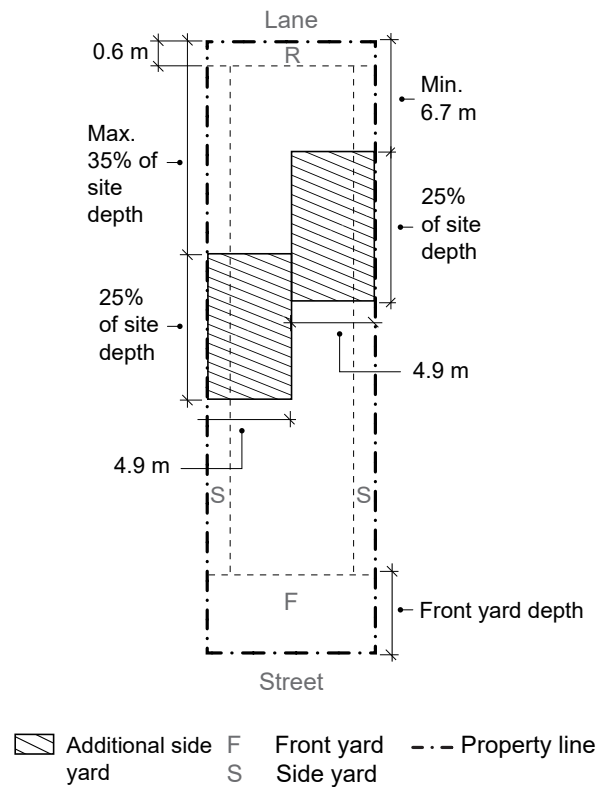

**Site Frontage**

- 3.1.2.11 The Director of Planning may decrease the minimum site frontage for:
- (a) duplex or duplex with secondary suite; and
  - (b) infill single detached house in combination with the retention of a character building existing on the site prior to January 1, 1940,

if the lot was on record in the Land Title Office prior to May 15, 2013, and the Director of Planning considers the quality and liveability of the resulting units, the impact on neighbouring properties, the intent of this schedule, and all applicable Council policies and guidelines.

### Building Height

3.1.2.12 Despite the maximum building height in section 3.1.2.3(b) above, the third storey must be a partial storey not exceeding 50% of the storey immediately below and must comply with section 4.6 of this schedule.

3.1.2.13 The Director of Planning may increase the maximum building height:

- (a) in section 3.1.2.3(a) above, to permit a third storey, if it does not exceed 60% of the storey immediately below; and
- (b) in sections 3.1.2.3(a)(ii) and 3.1.2.12 above,

if the Director of Planning considers the intent of this schedule and all applicable Council policies and guidelines.

### Front Yard

3.1.2.14 Despite the minimum front yard depth in section 3.1.2.4(b) above:

- (a) where an adjacent site is vacant, the next adjacent site that is not vacant will be used to determine the average;
- (b) if 1 or more of the adjacent sites front on a street other than that of the development site, or the adjacent sites are separated by a street or lane, or the Director of Planning is satisfied that 1 or more of the adjacent sites is an anomaly, then such adjacent sites will not be used in computing the average; and
- (c) where the site is adjacent to a flanking street or lane, the depth must equal the single adjacent site.

3.1.2.15 The Director of Planning may decrease the required front yard depth if the Director of Planning considers the intent of this schedule and all applicable Council policies and guidelines.

### Side Yard

3.1.2.16 Despite the minimum side yard width in section 3.1.2.5 above and despite section 10.4 of this by-law, if a corner site has:

- (a) a site located at its rear, with or without the intervention of a lane, which fronts on the street flanking the corner site; and
  - (b) a frontage greater than 18.3 m,
- the minimum side yard width is 2.4 m.

3.1.2.17 Despite the minimum side yard width in section **3.1.2.5** above, except for duplex or duplex with secondary suite on a site with one principal building, additional side yards must be provided with:

- (a) a minimum width of 4.9 m;
- (b) a minimum length equal to 25% of the site depth, measured from the ultimate rear property line; and
- (c) a rear boundary that is not less than 6.7 m or more than a distance equal to 35% of the site depth, measured from the ultimate rear property line,

except that the Director of Planning may decrease the required side yard width in this section **3.1.2.17** if the Director of Planning considers the intent of this schedule and all applicable Council policies and guidelines.

#### **Rear Yard**

3.1.2.18 Despite the minimum rear yard depth in section **3.1.2.6** above, where the rear property line does not abut a lane and a lane dedication is not required, a rear yard must have a minimum depth of 1.2 m, except that the Director of Planning may decrease the required rear yard if the Director of Planning considers the intent of this schedule and all applicable Council policies and guidelines.

#### **Building Depth**

3.1.2.19 The Director of Planning may increase the maximum building depth if the Director of Planning considers the intent of this schedule and all applicable Council policies and guidelines.

## 4 GENERAL REGULATIONS

All uses in these districts, except single detached house and single detached house with secondary suite, as the only principal building on the site, and laneway house, are subject to the following regulations.

### 4.1 Computation of Floor Area

#### 4.1.1 Computation of floor area must include:

- (a) all floors, including earthen floor, measured to the extreme outer limits of the building including accessory buildings;
- (b) stairways, fire escapes, elevator shafts and other features that the Director of Planning considers similar to the foregoing, measured by their gross cross-sectional areas and included in the measurements for each floor at which they are located; and
- (c) where the distance from a floor to the floor above, or where there is no floor above, to the top of the roof joists, exceeds 3.7 m, an amount equal to the area of the floor below the excess height.

#### 4.1.2 Computation of floor area must exclude:

- (a) balconies and decks, and any other appurtenances that the Director of Planning considers similar to the foregoing, provided that the total area of these exclusions does not exceed 8% of the permitted floor area;
- (b) patios and roof decks, if the Director of Planning considers the impact on privacy and overlook;
- (c) where floors are used for off-street parking and loading, bicycle storage in multiple conversion dwellings containing 3 dwelling units, or uses that the Director of Planning considers similar to the foregoing, those floors or portions thereof not exceeding 7.3 m in length, which:
  - (i) for dwelling uses on sites with 1 principal building, are located in an accessory building located on the site in accordance with sections [2.2.12](#) and [2.2.13](#) of this schedule or in an infill building up to a maximum of 48 m<sup>2</sup>,
  - (ii) for dwelling uses on sites with no developed secondary access and with only 1 principal building, are located in a principal building, an accessory building, or infill building up to a maximum area that the Director of Planning may determine, provided the Director of Planning considers the intent of this schedule and all applicable Council policies and guidelines,
  - (iii) for dwelling uses on sites with more than 1 principal building, are located in a principal building or an accessory building up to a maximum area of 24 m<sup>2</sup> per dwelling unit,
  - (iv) for dwelling uses on a site with no developed secondary access and with more than 1 principal building, are located in a principal building, or an accessory building up to a maximum area that the Director of Planning may determine, provided the Director of Planning considers the intent of this schedule and all applicable Council policies and guidelines, and
  - (v) for non-dwelling uses, are located at or below base surface;

- (d) areas of undeveloped floors that are located:
  - (i) above the highest storey or partial storey, and to which there is no permanent means of access other than a hatch, or
  - (ii) adjacent to a storey or partial storey with a ceiling height of less than 1.2 m;
- (e) floors located at or below finished grade with a ceiling height of less than 1.2 m;
- (f) entries, porches and verandahs, and covered porches above the first storey, if:
  - (i) the side facing the street, rear property line, common open space, park, or school is open or protected by guards that do not exceed the required minimum height,
  - (ii) the total area of these exclusions, when combined with the balcony and deck exclusions under section 4.1.2(a) above, does not exceed 13% of the permitted floor area,
  - (iii) the ceiling height, excluding roof structure, of the total area being excluded does not exceed 3.1 m measured from the entry, porch or verandah floor, and
  - (iv) for duplex and duplex with secondary suite, the depth of the total area being excluded for covered porches above the first storey does not exceed 1.8 m;
- (g) unconditioned floor areas with a ceiling height or height to the underside of joists of less than 2.0 m, located below the floors of entries, porches and verandahs complying with section 4.1.2(f) above, to which there is no access from the interior of the building; and
- (h) for duplex and duplex with secondary suite, areas of floors existing, proposed or as may be extended over open-to-below space located directly below sloping roof rafters or a sloping ceiling where the ceiling is directly attached to the underside of sloping roof rafters, and where the roof joists have a minimum 7:12 pitch and the related ceiling maintains the same pitch as the roof joists if:
  - (i) the distance from the floor to any part of the roof rafters or ceiling is no higher than 2.3 m and no lower than 1.2 m, both measured vertically, and
  - (ii) the excluded floor area does not exceed 10% of the permitted total floor area,

and despite the definition of “partial storey” in Section 2 of this by-law, for the purposes of this schedule the maximum permitted floor area contained in a partial storey must not include floor area excluded in this section 4.1.2(h).

## 4.2 Dwelling Unit Density: Calculation

- 4.2.1 Where the calculation of dwelling units, secondary suites or lock-off units results in a fractional number, the number must be rounded down.

### 4.3 Site Coverage and Impermeability

4.3.1 The maximum site coverage for any portion of the site used as parking area is 30%.

4.3.2 The maximum area of impermeable materials includes site coverage for all buildings.

### 4.4 Side Yards: Projections

4.4.1 Despite section 10.8 of this by-law:

- (a) entries, porches and verandahs complying with section 4.1.2(f) of this schedule may project up to 1.2 m into the required side yards, on corner sites with a side yard of at least 2.4 m;
- (b) steps that access the main level or basement or accommodate grade changes, or other projections that the Director of Planning considers similar to the foregoing, may project into the additional side yard required by section 3.1.2.17 of this schedule, except that they must not be closer than 2.4 m to a side property line; and
- (c) the Director of Planning may permit other projections into required side yards.

### 4.5 Building Depth: Measurement

4.5.1 Maximum building depth means the maximum distance between the required minimum front yard and the rear of the principal building closest to the front of the site, measured prior to any required lane dedication.

### 4.6 External Design

4.6.1 This section 4.6 applies to duplex and duplex with secondary suite on a site with 1 principal building.

4.6.2 For the purpose of this section 4.6, a “main entrance” means a door facing a street not being a lane, which is visible from the street and is located at or within 1.8 m of grade, or connected to grade by stairs or a ramp.

4.6.3 There must be 2 main entrances, 1 to each principal dwelling unit.

4.6.4 On a corner site, 1 main entrance must face the front street and 1 main entrance must face the flanking street.

4.6.5 There must be an entry, porch or verandah at each main entrance, with a minimum width and depth of 1.8 m.

4.6.6 Roof design must comply with the following provisions:

- (a) all roofs except for dormer roofs must:
  - (i) have a slope not less than 7:12 and not more than 12:12,

- (ii) be either hip or gable or a combination of both, and
  - (iii) intersect at its lower portion with the exterior wall face of the building or the vertical projection thereof at a line no higher than the lesser of 7.9 m above the base surface or the floor level of a partial storey or attic above the second storey;
- (b) dormer roofs must be gable, hip or shed in form and must have a minimum slope of 4:12;
  - (c) the maximum total width of dormers provided on a partial storey above the second storey must not exceed 50% of the width of the elevation of the storey below;
  - (d) all exterior dormer walls must be set back a minimum of 0.6 m from the exterior face of the wall of the storey below; and
  - (e) despite section 4.6.6(d) above, 1 dormer, which faces an interior side yard and which provides headroom over a stair and any intermediate and top landings that provide access from the second storey to the partial storey above may have its face wall flush or continuous with the second storey exterior wall face below.

4.6.7 Exterior windows in a secondary suite or lock-off unit must have a minimum total glazing area of:

- (a) 10% of the total floor area of the room, in each of the kitchen, living room and dining room; and
- (b) 5% of the total floor area of the room, in all other rooms, except bathrooms and laundry rooms.

4.6.8 The Director of Planning may vary the requirements of this section 4.6 if, in the opinion of the Director of Planning, the design meets the intent of the regulations for quality and durability of design and architectural expression.

## **4.7 Dedication of Land**

### **4.7.1 Dedication for lane purposes**

- 4.7.1.1 Where a site does not abut a lane, or abuts a lane that is less than 6.1 m in width, a portion of the site, as determined by the City Engineer, up to a maximum of 3.1 m, must be dedicated for lane purposes.
- 4.7.1.2 Where a dedication is made, it will be deemed not to reduce the site area for the purpose of calculating floor space ratio.