

RT-10 and RT-10N

Districts Schedule

1 INTENT AND OVERVIEW

1.1 Intent

The intent of this schedule is to encourage development of multiple small houses and duplexes on large lots and assembled sites, while continuing to permit lower intensity development on smaller sites. Siting and massing is intended to be compatible with, but not the same as, pre-existing single detached house development. Retention of older character buildings is encouraged. In the RT-10N district, acoustic regulations in [Section 10](#) of this by-law apply to dwelling units close to arterial streets.

Without limitation, applicable Council policies and guidelines for consideration include the [RT-10 and RT-10N Small House/Duplex Guidelines](#).

1.2 Overview

The table below provides an overview of the outright and conditional approval uses in the RT-10 and RT-10N districts, categorized by the minimum site area required, where applicable. Applicable density, form and placement regulations in section [3](#) of this schedule are cross-referenced in the third column.

Minimum Site Area	Use	Density, Form and Placement Regulations
511 m ²	Development with more than 1 principal building	3.1
306 m ²	Duplex	3.1
	Single Detached House or Single Detached House with Secondary Suite	3.1
	Multiple Conversion Dwelling	3.1
	Infill Single Detached House or Infill Duplex	3.1
--	Other uses in section 2.1 of this schedule	3.1

2 USE REGULATIONS

2.1 Outright and Conditional Approval Uses

All outright and conditional approval uses are subject to all other provisions of this by-law, including [Section 2](#), [Section 10](#) and [Section 11](#), and compliance with the regulations of this schedule including section [2.2](#).

The uses identified in the table below as outright approval uses are permitted in these districts and will be issued a permit.

The uses identified in the table below as conditional approval uses may be approved in these districts by the Director of Planning, with or without conditions, if the Director of Planning considers:

- (a) the intent of this schedule and all applicable Council policies and guidelines; and
- (b) the submission of any advisory group, property owner or tenant.

Uses are listed under their general land use category. Applicable use-specific regulations in section [2.2](#) of this schedule are cross-referenced in the third column. Cross-references to applicable use-specific regulations are provided for information purposes only and do not form part of this by-law.

Use	Approval	Use-Specific Regulations
Agricultural Uses		
Urban Farm - Class A	Conditional	
Cultural and Recreational Uses		
Club	Conditional	2.2.1
Community Centre or Neighbourhood House	Conditional	
Library, in combination with Community Centre	Conditional	
Park or Playground	Conditional	
Dwelling Uses		
Duplex	Conditional	
Infill Duplex	Conditional	
Infill Single Detached House	Conditional	
Mixed-Use Residential Building	Conditional	2.2.2
Multiple Conversion Dwelling, containing 2 dwelling units	Outright	2.2.3
Multiple Conversion Dwelling, not permitted as an outright approval use and resulting from the conversion of a building existing on the site as of November 23, 2005	Conditional	
Seniors Supportive or Independent Living Housing	Conditional	
Single Detached House	Outright	
Single Detached House with Secondary Suite	Conditional	

Use	Approval	Use-Specific Regulations
Institutional Uses		
Ambulance Station	Conditional	
Child Day Care Facility	Conditional	
Church	Conditional	
Community Care or Assisted Living Facility - Class A	Outright	2.2.4
Community Care or Assisted Living Facility - Class B	Conditional	
Group Residence	Conditional	
Hospital	Conditional	
Public Authority Use, essential in these districts	Conditional	
School - Elementary or Secondary	Conditional	
Social Service Centre	Conditional	
Office Uses		
Temporary Sales Office	Conditional	
Retail Uses		
Farmers' Market	Conditional	2.2.5
Neighbourhood Grocery Store	Conditional	
Public Bike Share	Conditional	
Shared E-Scooter System	Conditional	
Service Uses		
Bed and Breakfast Accommodation	Conditional	
Short Term Rental Accommodation	Conditional	
Utility and Communication Uses		
Public Utility	Conditional	
uncategorized		
Accessory Buildings, customarily ancillary to any use listed in this section 2.1	Outright	2.2.6 , 2.2.7
Accessory Buildings, customarily ancillary to any use listed in this section 2.1 and not permitted as an outright approval use	Conditional	
Accessory Uses, customarily ancillary to any outright approval use listed in this section 2.1	Outright	
Accessory Uses, customarily ancillary to any conditional approval use listed in this section 2.1	Conditional	
Deposition or extraction of material, which alters the configuration of the land	Conditional	

2.2 Use-Specific Regulations

- 2.2.1 Club may be permitted if no commercial activities are carried on and the use does not adversely impact dwelling uses.
- 2.2.2 The only non-dwelling use permitted in a mixed-use residential building is neighbourhood grocery store.
- 2.2.3 Multiple conversion dwelling containing 2 dwelling units is permitted as an outright approval use if:
 - (a) there are no additions to the building;
 - (b) no housekeeping or sleeping units are created; and
 - (c) no development permit is issued until the requisite permits required by other by-laws that relate to design, construction and safety of buildings are issuable.
- 2.2.4 Community care or assisted living facility - class A is subject to the regulations, variations and relaxations that apply to single detached house.
- 2.2.5 Farmers' market may be permitted if the Director of Planning considers the appropriateness of the use with respect to compatibility with nearby sites, parking, traffic, noise, hours of operation, size of facility and pedestrian amenity.

2.2.6 Accessory buildings customarily ancillary to any use listed in section 2.1 of this schedule, are permitted as an outright approval use if:

- (a) no accessory building exceeds 3.7 m in height, measured to:
 - (i) the highest point of a flat roof,
 - (ii) the deck line of a mansard roof, or
 - (iii) the mean height between the eaves and the ridge of a gable, hip or gambrel roof,
 provided that no portion of an accessory building exceeds 4.6 m in building height;
- (b) all accessory buildings are located:
 - (i) within 7.1 m of the ultimate rear property line,

Diagram: Building placement for accessory building

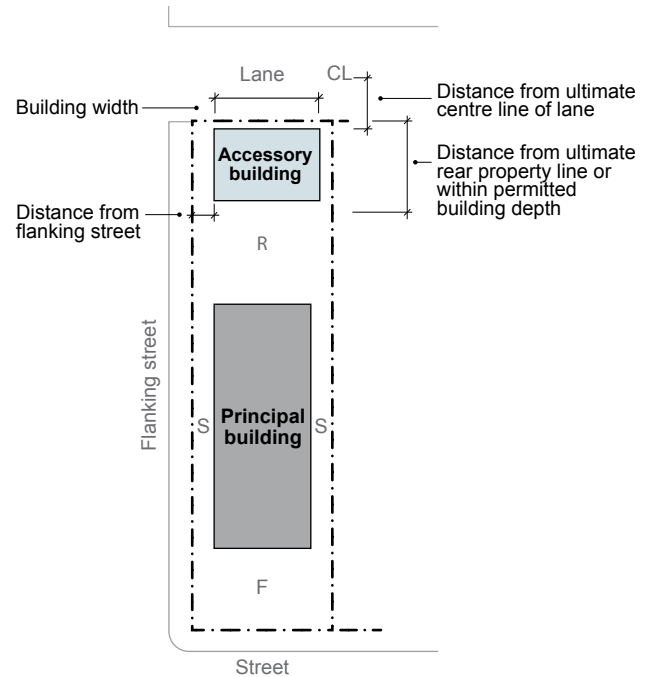

CL	Centre line	F	Front yard
R	Rear yard	- - -	Property line
S	Side yard		

- (ii) at least 3.6 m from the ultimate centre line of any rear or flanking lane, and
- (iii) at least 1.5 m from a flanking street;
- (c) the total floor area of all accessory buildings, measured to the extreme outer limits of the building, does not exceed 48 m²;
- (d) the combined building width for all accessory buildings does not exceed 80% of the width of the site at the rear property line; and
- (e) roof decks and decks are not located on an accessory building.

2.2.7 The Director of Planning may vary the floor area and site coverage regulations for accessory buildings and sections 4.7 and 4.8 of the [Parking By-law](#) provided that:

- (a) the Director of Planning is satisfied that adequate off-street parking on any site less than 36.6 m in depth cannot otherwise be accommodated; and
- (b) in developments with a carport or garage, the Director of Planning considers the impact on neighbouring sites of building height, shadow, open space and landscaping.

3 DENSITY, FORM AND PLACEMENT REGULATIONS

This section contains density, form and placement regulations organized by use.

3.1 All Uses

Duplex, single detached house, single detached house with secondary suite, multiple conversion dwelling, infill, dwelling uses on a site with more than 1 principal building, and all other uses in these districts are subject to the following regulations.

3.1.1 Density and Floor Area

3.1.1.1 The maximum floor space ratio is 0.40, except that the Director of Planning may increase the permitted floor space ratio to a maximum of:

- (a) 0.80 for dwelling uses; and
- (b) 0.60 for all other uses combined,

if the Director of Planning considers the intent of this schedule, all applicable Council policies and guidelines and the submission of any advisory group, property owner or tenant.

3.1.1.2 The total number of dwelling units on a site must not exceed:

- (a) 74 units per hectare on sites with a site frontage of 18.3 m or more;
- (b) 3 dwelling units on sites with a site frontage that is equal to or greater than 15.0 m but is less than 18.3 m; and
- (c) 2 dwelling units on sites with a frontage less than 15.0 m,

except that the Director of Planning may vary the permitted number of dwelling units on a site if the Director of Planning considers the intent of this schedule and all applicable Council policies and guidelines, but the Director of Planning may not increase the number of dwelling units to more than 3 for section [3.1.1.2\(c\)](#) above.

3.1.2 Building Form and Placement

Regulations	RT-10 and RT-10N
3.1.2.1 Minimum site area for:	306 m ²
(a) duplex	
(b) single detached house or single detached house with secondary suite	
(c) multiple conversion dwelling	

Regulations	RT-10 and RT-10N
(d) infill duplex and infill single detached house	306 m ²
3.1.2.2 Maximum building height for a building located:	
(a) in the front 60% of the site depth	10.7 m and 2 storeys
(b) in the rear 40% of the site depth	7.7 m and 2 storeys
3.1.2.3 Minimum front yard depth on:	
(a) sites with a frontage greater than 18.3 m and with more than 1 principal building	4.9 m
(b) other sites	the average of the minimum front yard depths of the 2 adjacent sites
3.1.2.4 Minimum side yard width where the site width:	
(a) does not exceed 12.0 m	10% of the site width
(b) exceeds 12.0 m	1.2 m
3.1.2.5 Minimum rear yard depth	0.6 m
3.1.2.6 Maximum site coverage for all buildings	45% of the site area
3.1.2.7 Maximum area of impermeable materials	70% of the site area
3.1.2.8 Maximum building depth for sites where there is 1 principal building or 1 principal building with infill	40% of the site depth

Number of Principal Buildings on a Site

3.1.2.9 The Director of Planning may permit more than 1 principal building on sites with a minimum site area of 511 m² and a minimum site frontage of 15.0 m, if the Director of Planning considers the intent of this schedule and all applicable Council policies and guidelines.

Site Area

3.1.2.10 The Director of Planning may reduce the minimum site area in sections [3.1.2.1\(a\)](#) and [3.1.2.1\(b\)](#) above if the lot was on record in the Land Title Office prior to November 23, 2005.

Building Height

3.1.2.11 Despite the maximum building height in section [3.1.2.2\(b\)](#) above, the second storey of a building located in the rear 40% of the site depth must be a partial storey not exceeding 50% of the storey immediately below.

3.1.2.12 The Director of Planning may increase the maximum building height, if the Director of Planning considers the intent of this schedule and all applicable Council policies and guidelines.

Front Yard

3.1.2.13 Despite the minimum front yard depth in section 3.1.2.3(b) above:

- (a) where an adjacent site is vacant, the next adjacent site that is not vacant will be used to determine the average;
- (b) if 1 or more of the adjacent sites front on a street other than that of the development site, or the adjacent sites are separated by a street or lane, or the Director of Planning is satisfied that 1 or more of the adjacent sites is an anomaly, then such adjacent sites will not be used in computing the average; and

(c) where the site is adjacent to a flanking street or lane, the depth must equal the single adjacent site.

3.1.2.14 The Director of Planning may vary the required front yard depth on:

- (a) a corner site;
- (b) a double fronting site;
- (c) a site where a building line has been established pursuant to section 8.1.1 of this by-law; and
- (d) other sites,

if the Director of Planning considers the intent of this schedule and all applicable Council policies and guidelines.

Side Yard

3.1.2.15 Despite the minimum side yard width in section 3.1.2.4 above, in the case of a corner site that has located at its rear, with or without the intervention of a lane, a site that fronts on the street flanking the corner site, the required minimum width of an exterior side yard is 2.4 m.

3.1.2.16 Despite the minimum side yard width in section 3.1.2.4 above, an additional side yard with a minimum width of 4.9 m and minimum length equal to 25% of the site depth must also be provided on each side of

Diagram: Yards for principal building

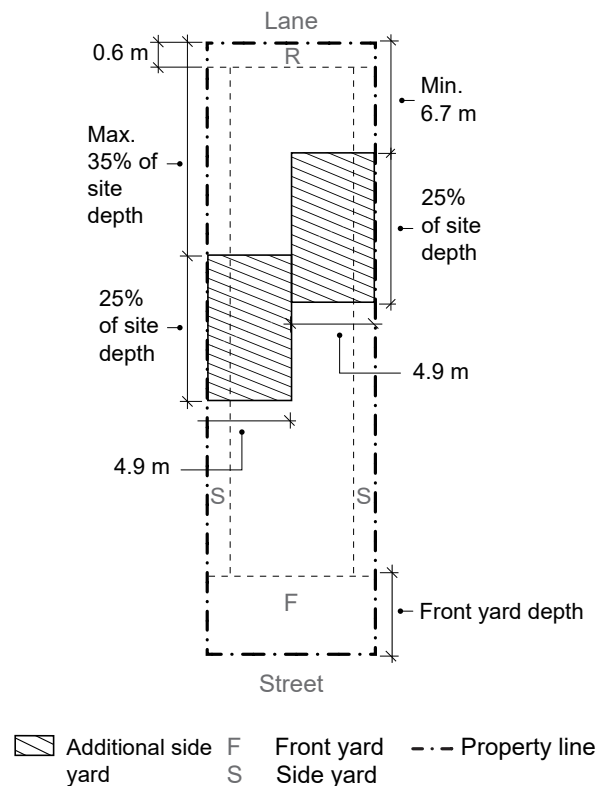

the site, and each of these side yards must be located so that its rear boundary is not less than 6.7 m, and not more than a distance equal to 35% of the site depth, from the ultimate rear property line.

3.1.2.17 The Director of Planning may vary the required side yard width on:

- (a) a corner site;
- (b) a double fronting site;
- (c) a site where a building line has been established pursuant to section **8.1.1** of this by-law; and
- (d) other sites,

if the Director of Planning considers the intent of this schedule and all applicable Council policies and guidelines.

Rear Yard

3.1.2.18 Despite the minimum rear yard depth in section **3.1.2.5** above, where the rear property line does not abut a lane and a lane dedication is not required, a rear yard with a minimum depth of 1.2 m must be provided, except that the Director of Planning may increase the required rear yard if the Director of Planning considers the intent of this schedule and all applicable Council policies and guidelines.

Building Depth

3.1.2.19 The Director of Planning may increase the maximum building depth if the Director of Planning considers the intent of this schedule and all applicable Council policies and guidelines.

4 GENERAL REGULATIONS

All uses in these districts are subject to the following regulations.

4.1 Computation of Floor Area

4.1.1 Computation of floor area must include:

- (a) all floors, including earthen floor, measured to the extreme outer limits of the building including accessory buildings;
- (b) stairways, fire escapes, elevator shafts, and other features that the Director of Planning considers similar to the foregoing, measured by their gross cross-sectional areas and included in the measurements for each floor at which they are located; and
- (c) where the distance from a floor to the floor above, or where there is no floor above, to the top of the roof joists, exceeds 3.7 m, an amount equal to the area of the floor below the excess height.

4.1.2 Computation of floor area must exclude:

- (a) balconies and decks, and any other appurtenances that the Director of Planning considers similar to the foregoing, provided that the total area of these exclusions does not exceed 8% of the permitted floor area;
- (b) patios and roof decks, if the Director of Planning considers the impact on privacy and overlook;
- (c) where floors are used for off-street parking and loading, bicycle storage in multiple conversion dwellings containing 3 or more dwelling units, or uses that the Director of Planning considers similar to the foregoing, those floors or portions thereof not exceeding 7.3 m in length, which:
 - (i) for dwelling uses:
 - (A) on sites with only 1 principal building, are located in an accessory building located on the site in accordance with sections 2.2.6 and 2.2.7 of this schedule or in an infill building up to a maximum of 48 m²,
 - (B) on sites with no developed secondary access and with only 1 principal building, are located in a principal building, an accessory building, or an infill building up to a maximum area that the Director of Planning may determine, provided the Director of Planning considers the intent of this schedule and all applicable Council policies and guidelines,
 - (C) on sites with more than 1 principal building, are located in a principal building or an accessory building up to a maximum area of 24 m² per dwelling unit, and
 - (D) on sites with no developed secondary access and with more than 1 principal building, are located in a principal building, or an accessory building up to a maximum area that the Director of Planning may determine, if the Director of Planning considers the intent of this schedule and all applicable Council policies and guidelines, and
 - (ii) for non-dwelling uses, are located at or below base surface;

- (d) areas of undeveloped floors that are located:
 - (i) above the highest storey or partial storey, and to which there is no permanent means of access other than a hatch, or
 - (ii) adjacent to a storey or partial storey with a ceiling height of less than 1.2 m;
- (e) floors located at or below finished grade with a ceiling height of less than 1.2 m;
- (f) entries, porches and verandahs, and covered porches above the first storey, if:
 - (i) the side facing the street, rear property line or common open space is open or protected by guards that do not exceed the required minimum height,
 - (ii) the total area of these exclusions, when combined with the balcony and deck exclusions under section 4.1.2(a) above, does not exceed 13% of the permitted floor area,
 - (iii) the ceiling height, excluding roof structures, of the total area being excluded does not exceed 3.1 m measured from the entry, porch or verandah floor; and
- (g) unconditioned floor areas with a ceiling height or height to the underside of joists of less than 2.0 m, located below the floors of entries, porches and verandahs complying with section 4.1.2(f) above, to which there is no access from the interior of the building.

4.2 Dwelling Unit Density: Calculation

- 4.2.1 On sites with a frontage of 18.3 m or more, where the calculation of dwelling units per hectare results in a fractional number, the number must be rounded down.

4.3 Site Coverage and Impermeability

- 4.3.1 The maximum site coverage for any portion of the site used as parking area is 30%.
- 4.3.2 The maximum area of impermeable materials includes site coverage for all buildings.

4.4 Yards: Projections

- 4.4.1 Despite section 10.8 of this by-law:
 - (a) entries, porches and verandahs complying with section 4.1.2(f) of this schedule may project up to 1.2 m into the required side yards, where a side yard of at least 2.4 m in width has been provided; and
 - (b) the Director of Planning may permit other projections in the required side yards if the Director of Planning considers the intent of this schedule and all applicable Council policies and guidelines.

4.5 Building Depth: Measurement

- 4.5.1 Maximum building depth means the maximum distance between the required minimum front yard and the rear of the principal building, measured prior to any required lane dedication.

4.6 External Design

- 4.6.1 A portion of the surface of the ground adjoining a building may be lowered and excluded from the average elevation for the purpose of calculating finished grade, if:
- (a) the purpose is to provide light or access to a basement or cellar;
 - (b) the lowered surface does not extend more than 3.1 m from the building;
 - (c) that portion of the building abutting the lowered surface does not exceed half the width of the building, or 4.6 m, whichever is the lesser; and
 - (d) the lowered surface does not extend into the side yard required in sections [3.1.2.4](#).