

# Bulletin

## Parking and Loading Design Supplement

*Effective July 12, 1988*

*Last amended January 17, 2023*

*Authority: Director of Planning and City Engineer*

As part of the Engineering Department's review of rezoning and development permit applications, the Transportation Planning Branch examines development drawings to ensure that parking and loading designs meet City bylaws and guidelines for safe, functional access. As a supplement to the information contained in the Parking By-law, the following has been compiled to assist in the drafting of plans and to avoid confusion and delay. In conjunction with these guidelines, good engineering practices are to be followed in all circumstances to ensure public safety.

# 1 Ramp Design

## 1.1 Ramp Grades

The maximum ramp slope allowed in the first 6.1 m from the property line is 10%. The maximum slope after the first 6.1 m from the property line is 12.5%. On extreme hardship sites, slopes up to 15% may be acceptable if a 7.5% to 10% transition ramp or continuous transition curve is provided at the bottom for at least 4 m in length. Ramps which have a 15% slope and are exposed to the weather must be heated.

Please note that the percent of slope, the length of the ramp at the specified slope, and design elevations on both sides of the ramp at all break points (plus along the centre of travel lanes in curves) must be shown on the submitted drawings.

## 1.2 Ramp Widths

**Table 1: Minimum Ramp Widths**

| To/From                      | Number of Parking Spaces | Minimum Width |
|------------------------------|--------------------------|---------------|
| A Residential Street or Lane | 19 or fewer              | 3.6 m         |
| A Residential Street or Lane | 20 or more               | 6.1 m         |
| An Arterial Street           | 9 or fewer               | 3.6 m         |
| An Arterial Street           | 10 or more               | 6.1 m         |

**Note 1:** Where views to pedestrians would otherwise be obstructed, diagonal corner cuts or view portals are required. View portals at the top or bottom of ramps within underground parking areas may also be required to provide improved visibility of oncoming vehicles.

**Note 2:** Corner cuts are required at the top and bottom of ramps to provide adequate radii for continuous two-way traffic flow where 200 or more vehicles are being served. A standard 6 m ramp width would require a 2.7 m x 2.7 m corner cut. Reduced corner cuts would be acceptable for wider ramps upon review.

## 1.3 Convex Mirrors on Ramps

Convex mirrors are required at those locations, such as 90-degree jogs in access ramps, where opposing motorists cannot readily view each other. The condition normally applies to a ramp which is too narrow to permit vehicles to bypass each other.

## 1.4 Security Door Controls

If a key lock or similar security system is to be used on a driveway designed for two-way movement, the activation unit must be placed in the middle of the ramp, and the ramp should be at least 6.7 m wide. Where a driveway with two-way movement is of lesser width, the overhead security door shall be activated by a remote control unit in the vehicle. This should be noted on submitted drawings. Where the driveway is accessed from a street, as opposed to a lane, the

security door (and activation unit, if applicable) shall be positioned such that a vehicle is off the City street when stopped to activate the door.

## 2 Parking Area

### 2.1 Parking Space Size

**Table 2: Minimum Parking Space Dimensions**

| Parking Space Type        | Minimum Dimensions  |
|---------------------------|---|
| Standard vehicle space    | 5.5 m (L) x 2.5 m (W)   |
| Small car space           | 4.6 m (L) x 2.3 m (W)   |
| Standard accessible space | 5.5 m (L) x 4.0 m (W)   |
| Van accessible space      | Independent: 5.5 m (L) x 5.0 m (W) x 2.3 m (H)                            |
|                           | Shared: 5.5 m (L) x 3.5 m (W) x 2.3 m (H) + 1.5 m shared access aisle (W) |

**Note 1:** If a parking stall is adjacent to a wall, or if a column is located more than 1.2 m from either end of the stall, then the required stall width is 2.7 m for a standard vehicle, and 2.6 m for a small car.

**Note 2:** If column encroachments are proposed, the following minimum standards must be satisfied (see Appendix):

- (a) A 3-vehicle span for general purpose parking requires a minimum width of 7.5 m with a maximum of 0.15 m column encroachment. The three-vehicle span design accommodates one (1) van-accessible space for one (1) accessible space with a shared access aisle. Note: this restricts columns to a maximum 0.3 m width centred on the stall dividing line.
- (b) Any column encroachment on a 2.5 m wide parking stall must be set back from the manoeuvring aisle, yet respect the 1.2 m maximum limit from the end of the stall. For example, if the column depth is 0.6 m long, then it must be set back 0.6 m from a standard 6.6 m manoeuvring aisle. However, if a proposed manoeuvring aisle exceeds the 6.6 m minimum, the column need not be set back as far. For example, the minimum required column setback from a 6.9 m manoeuvring aisle is 0.3 m and from a 7.2 m manoeuvring aisle is nil. Should a column 0.9 m long be required, then it must be set back 0.3 m, but a standard width manoeuvring aisle is acceptable.
- (c) No column encroachments will be accepted for single stall modules having columns on both sides of the stall. Furthermore, although there are no column encroachments, submissions as per this example will still require columns to be set back as per (b).
- (d) Column encroachments up to 0.15 m on small car stalls are also acceptable provided the required setbacks as noted in (b) above are met.

- Note 3:**
- (a) If accessible spaces are located beside one another or beside a walkway or open area, then they can be 2.5 m wide with a wheelchair accessible 1.5 m wide access corridor (see Appendix).
  - (b) Each required accessible space can count as two standard parking spaces toward meeting minimum total required parking.

## 2.2 Projections over a Stall

Projections over a stall normally occur with shallow sites which require an overlapping split-level design for the parking structure. If projections are unavoidable due to site constraints, they should meet the following design criteria. Vertical clearance must not be less than 1.2 m and projection into the stall from the wall must not be more than 1.2 m. The corner of such projection is to be chamfered at 45 degrees for a minimum of 10 cm and the vertical face of at least every other stall marked "CAUTION - LOW CLEARANCE" in minimum 10 cm high black letters on a yellow background.

## 2.3 Manoeuvring Aisle Width

Generally where the parking stall is aligned at a 90-degree angle to the wall, a 6.6 m wide manoeuvring aisle is required. The manoeuvring aisle width may be reduced for small car stalls, or if the angle of parking is less than 90 degrees upon review by Engineering staff. In cases where provision of parking is difficult, a limited reduction of the manoeuvring aisle width for 90-degree stalls may be permitted to an absolute minimum of 6.1 m provided that the minimum width of the parking stall accessed is greater than standard (see Appendix). No widening is required for small car spaces, however.

**Note:** Manoeuvring aisles are, in effect, a hammerhead access to and from parking spaces. Except for some entrances and the dead-end portion of a parking layout, the effective manoeuvring aisle width on either side of a parking space is not to be restricted by elevator cores, stairwells, or other obstructions.

SEE ATTACHED GUIDELINES FOR ADDITIONAL DIMENSION  
REQUIREMENTS FOR PARKING AREAS (APPENDIX)

## 2.4 Access, Circulation and Parking Layout

Because of the complexity of factors entering into the determination of the location of points of access to a site, applicants should discuss this aspect of a development at an early date with Engineering staff. The following items should be considered for circulation:

- Right hand drive should be maintained onto, on, and from the site, except that where access is taken from the left side of a one-way street, a left hand drive entrance/exit ramp may be suitable.
- Design of on-site circulation should be logical and efficient.
- Circuitous routings to obscure parking or loading areas should be avoided.
- Parking must be laid out such that it does not require a vehicle to back up for more than 10 m.
- Parking layouts must be such that vehicles exit the parking area in a forward direction, except where the lane serves as the manoeuvring aisle or in RS and RT zoning.
- In those cases where a parking stall requires that a vehicle make a 180 degree turn, adequate area must be provided so this may be accomplished without undue difficulty.
- Interior access, circulation, and manoeuvring areas serving any accessible parking space must also provide minimum 2.3 m vertical clearance.

- In residential parking facilities, visitor spaces should be clearly marked on submitted plans and located outside a security gate separating them from parking for residents' vehicles.

The following items should be considered in the parking layout:

- In parking structures, the location of short-term transient parking should be convenient to the ground level.
- Each parking stall must be numbered on the drawings so that it may be uniquely identified by reviewing staff.
- All small car stalls must be clearly marked on submitted plans and the small car ratio noted. See the Parking By-law, Section 4.1.8 regarding the permitted proportions of small cars.
- The normally allowable maximum slope or crossfall is 5%, applicable to both the parking stalls and access aisles.

## 2.5 Ticket Dispensers

Ticket dispensers with automatic gates normally must be located not less than 15 m inside the property line measured along the driveway centreline. At entrances where an attendant controls entry and exit, the booth normally must be located not less than 30 m from the property line measured along the driveway centreline. If the attendant only controls the exit lane, then the 15 m distance will apply.

# 3 Loading and Passenger Spaces

## 3.1 Loading Space Standards

The Class A loading space allows for provision of spaces sized to serve vans or pick-up trucks. Dimensions are a minimum 2.7 m x 5.5 m. Except for where parallel parking occurs, in which case a minimum stall length of 6.4 m is required. Class A loading spaces must provide a minimum vertical clearance of 2.3 m. Interior access, circulation, and manoeuvring areas serving any Class A loading must also provide minimum 2.3 m vertical clearance.

Class B loading spaces have minimum dimensions of 3.0 m x 8.5 m. On narrow lots, 7.6 m to 10 m in width, a reduction in loading bay width to 2.7 m may be acceptable depending on site constraints and the vehicles to be served. For parallel spaces, a minimum 10.7 m of stall length is required. Where loading access from an arterial street is proposed on a conditional site, or in a rezoning, additional interior vertical clearance may be required. Provision of a clear unloading area or raised rear dock, minimum 1.8 m wide, with suitable access to facilitate goods loading/unloading is required. Alternatively, an overhead door, or an access corridor leading to an entry door may be provided. For smaller developments on narrow lots, an entry door at the end of a loading space is normally sufficient. For throat width requirements and width of second or subsequent loading spaces (see Section E of the Appendix). A double throat to facilitate manoeuvring to and from both directions should be provided where roadway network access is restricted and/or to facilitate access from the City's truck route network.

Dimensions for a Class C loading spaces are described in Section 5.5 of the Parking By-law.

Additional design considerations:

- The maximum slope or cross fall normally permitted in a loading space or access aisle is 5%.
- The maximum slope normally permitted for ramps intended to service Class B or Class C loading is 10%.

- Convenient, internal, stair-free access to and from all land uses should be provided on mixed-use sites for all loading spaces provided.

### **3.2 Passenger Space Standards**

Except for the first Class A passenger space for any site, which must be a minimum width of 4.0 m, the minimum width of spaces must be 2.9 m with a vertical clearance of 2.3 m. The minimum length of all spaces, including the first Class A passenger space must be 5.5 m. Except that for where parallel parking occurs, the minimum length must be 6.5 m. Where required by the Parking By-law or applicable area plan, at least one (1) Class A passenger space should be accommodated at-grade, accessed from the lane of all new development to provide accessible short term parking, pick-up and drop-off space.

The first required Class B passenger space (custom transit vehicle or HandyDart) is 4.0 m x 7.5 m with a vertical clearance of 3.5 m. Any additional space can have a reduced length of 6.0 m. All Class B spaces shall have a 4.0 m x 3.0 m landing area extending beyond the head of the space. For throat width requirements and landing area illustration, see Appendix.

Dimensions for a Class C passenger space (tour bus) are described in section 7.5 of the Parking By-law.

## **4 Other Considerations**

### **4.1 Motorcycles**

A stall designated for the parking of a motorcycle shall be a minimum of 1.5 m wide and 2.4 m long and clearly marked “Motorcycle Parking”.

**Note:** Motorcycle stalls do not count toward minimum vehicle parking spaces required under the Parking By-law. There is no minimum requirement for motorcycle spaces.

### **4.2 Bicycles**

Bicycle space regulations are set out in Section 6 of the Parking By-law.

## Appendix: Requirements for Parking Spaces

| A/ PARKING STALL GUIDELINES (MINIMUM STALL WIDTHS) |                    |       |                     |  |                   |                         |                    |       |                     |       |                   |
|--|--------------------|-------|---------------------|--|-------------------|-------------------------|--------------------|-------|---------------------|-------|-------------------|
| ANGLE PARKING TABLE (all dimensions in metres)     |                    |       |                     | ANGLE PARKING TABLE (all dimensions in feet) |                   |                         |                    |       |                     |       |                   |
| PARKING ANGLE (degrees)                            | DEPTH OF STALL (D) |       |                     |  | REQ'D AISLE WIDTH | PARKING ANGLE (degrees) | DEPTH OF STALL (D) |       |                     |       | REQ'D AISLE WIDTH |
|  | SMALL CARS (W=...) |       | NORMAL CARS (W=...) |  |                   |                         | SMALL CARS (W=...) |       | NORMAL CARS (W=...) |       |                   |
|  | 2.30               | 2.60* | 2.50                | 2.70*  |                   |                         | 7.55               | 8.53* | 8.20                | 8.86* |                   |
| PARALLEL   | -                  | -     | ** SEE NOTE**       |  | 3.6               | PARALLEL                | -                  | -     | ** SEE NOTE **      |       | 11.8              |
| 20   | 3.73               | 4.02  | 4.23                | 4.42   | 3.6               | 20                      | 12.3               | 13.2  | 13.9                | 14.5  | 11.8              |
| 25   | 4.03               | 4.30  | 4.59                | 4.77   | 3.6               | 25                      | 13.2               | 14.1  | 15.1                | 15.7  | 11.8              |
| 30   | 4.29               | 4.55  | 4.92                | 5.09   | 3.6               | 30                      | 14.1               | 14.9  | 16.1                | 16.7  | 11.8              |
| 35   | 4.52               | 4.77  | 5.20                | 5.37   | 3.6               | 35                      | 14.8               | 15.6  | 17.1                | 17.6  | 11.8              |
| 40   | 4.72               | 4.95  | 5.45                | 5.60   | 3.6               | 40                      | 15.5               | 16.2  | 17.9                | 18.4  | 11.8              |
| 45   | 4.88               | 5.09  | 5.66                | 5.80   | 3.6               | 45                      | 16.0               | 16.7  | 18.6                | 19.0  | 11.8              |
| 50   | 5.00               | 5.20  | 5.82                | 5.95   | 3.9               | 50                      | 16.4               | 17.0  | 19.1                | 19.5  | 12.8              |
| 55   | 5.09               | 5.26  | 5.94                | 6.05   | 4.2               | 55                      | 16.7               | 17.3  | 19.5                | 19.9  | 13.8              |
| 60   | 5.13               | 5.28  | 6.01                | 6.11   | 4.5               | 60                      | 16.8               | 17.3  | 19.7                | 20.1  | 14.8              |
| 65   | 5.14               | 5.27  | 6.04                | 6.13   | 4.8               | 65                      | 16.9               | 17.3  | 19.8                | 20.1  | 15.8              |
| 70   | 5.11               | 5.21  | 6.02                | 6.09   | 5.1               | 70                      | 16.8               | 17.1  | 19.8                | 20.0  | 16.7              |
| 75   | 5.04               | 5.12  | 5.96                | 6.01   | 5.4               | 75                      | 16.5               | 16.8  | 19.6                | 19.7  | 17.7              |
| 80   | 4.93               | 4.98  | 5.85                | 5.89   | 5.8               | 80                      | 16.2               | 16.3  | 19.2                | 19.3  | 19.0              |
| 85   | 4.78               | 4.81  | 5.70                | 5.71   | 6.2               | 85                      | 15.7               | 15.8  | 18.7                | 18.8  | 20.3              |
| 90   | 4.60               | 4.60  | 5.50                | 5.50   | 6.6               | 90                      | 15.1               | 15.1  | 18.0                | 18.0  | 21.7              |

\* These increased widths may be required (see section II, PARKING AREA A, Note 1:)

The diagram illustrates the geometry of a parking stall. It shows a top-down view of a row of stalls. Key dimensions are labeled: 'D' is the depth of the stall, 'W' is the width, 'L' is the length, and 'a' is the angle from the front edge to the side edge. 'AW' represents the required minimum aisle width. 'X1' is the space between stalls, 'X2' is the length of the aisle from the front edge to the back edge, and 'X3' is the width of the aisle from the side edge to the back edge.

**NOTE:**  
Parallel parking stalls shall be 2.5m x 6.4m with 3.6m aisle width

**PARKING STALL LAYOUT**  
(1) SELECT  
W = parking stall width  
L = parking stall length  
a = parking angle (degrees)

(2) LOOK UP IN TABLES:  
D = depth of parking stalls  
AW = required minimum aisle width

(3) ADDITIONAL LAYOUT INFORMATION  
X1 = space between stalls =  $W/\sin(a)$   
X2 =  $L \cos(a)$   
X3 =  $W \sin(a)$

B/ GUIDELINES FOR WIDENING STALL WIDTHS TO MINIMIZE AISLE WIDTHS (all dimensions in metres)

Aisle width (AW) may be decreased to a minimum of 6.1m (20ft) by increasing stall widths above the minimum requirement. Decreased aisle width can be determined by taking the aisle width for a given minimum stall width and applying to it the factor listed below in the second column. The factor that may be used depends on the size of the increased stall width as listed below in the first column. This six columns on the right are examples of decreased aisle widths that can be obtained using these factors.

| VALUES FOR DECREASING AISLE WIDTHS |        | EXAMPLES OF VARIOUS MINIMUM AISLE WIDTHS APPLIED TO FACTORS |                      |                      |                      |                      |                                |
|------------------------------------|--------|---|----------------------|----------------------|----------------------|----------------------|--------------------------------|
| STALL WIDTH                        | FACTOR | 90 degrees<br>6.6m**  | 80 degrees<br>5.8m** | 70 degrees<br>5.1m** | 60 degrees<br>4.5m** | 50 degrees<br>3.9m** | 45 degrees (or less)<br>3.6m** |
| 2.30 - 2.54*                       | 1.00   | 6.60  | 5.80                 | 5.10                 | 4.50                 | 3.90                 | 3.60                           |
| 2.55 - 2.59                        | .985   | 6.50  | 5.71                 | 5.02                 | 4.43                 | 3.84                 | 3.55                           |
| 2.60 - 2.64                        | .970   | 6.40  | 5.63                 | 4.95                 | 4.37                 | 3.78                 | 3.49                           |
| 2.65 - 2.69                        | .955   | 6.30  | 5.54                 | 4.87                 | 4.30                 | 3.72                 | 3.44                           |
| 2.70 - 2.74                        | .939   | 6.20  | 5.45                 | 4.79                 | 4.23                 | 3.66                 | 3.38                           |
| 2.75 +                             | .924   | 6.10  | 5.34                 | 4.71                 | 4.16                 | 3.60                 | 3.35                           |

\* up to 2.54m is considered to be no increase above minimum stall width.

\*\* minimum aisle width for minimum stall width (2.54m or less)

C/ COLUMN ENCROACHMENT REQUIREMENTS (all dimensions in metres)

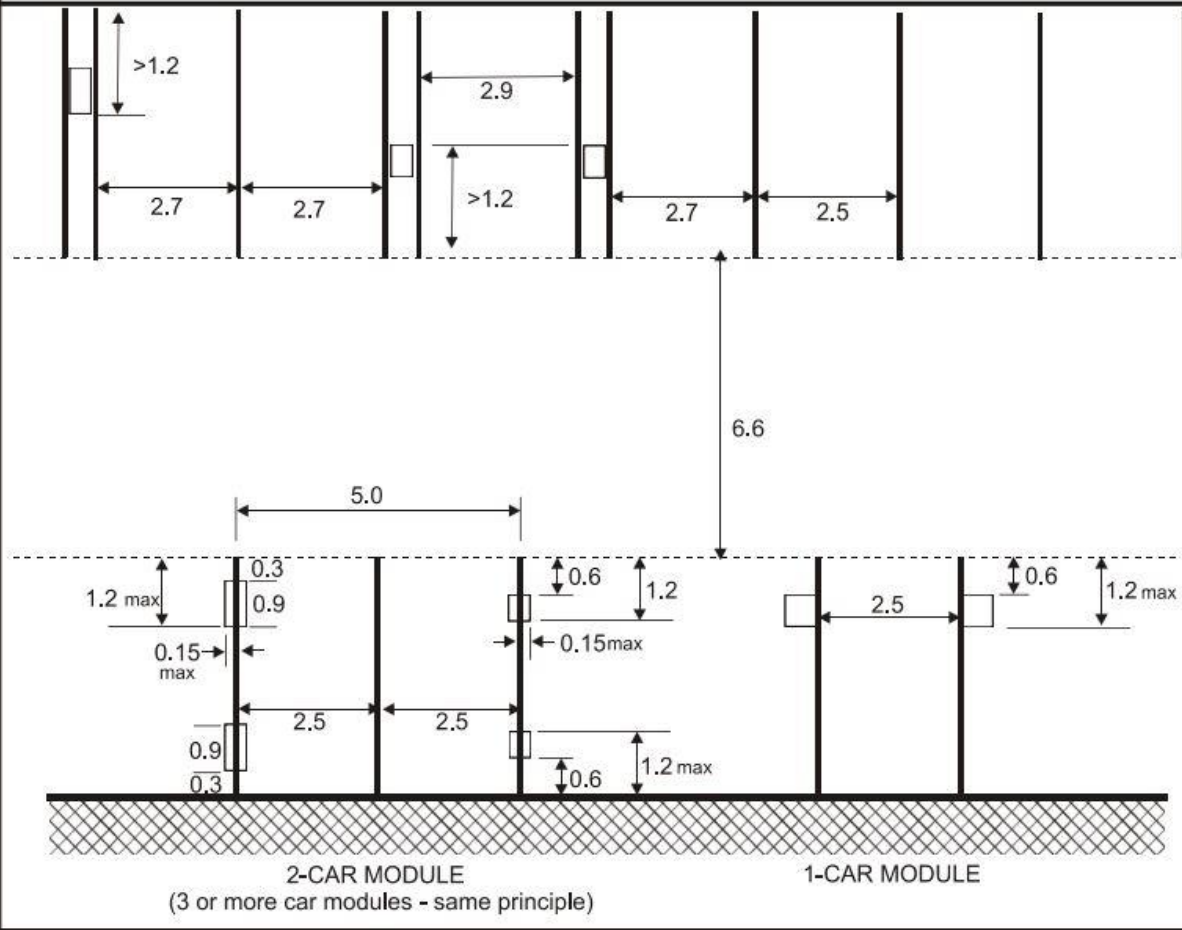



D/ ACCESSIBILITY SPACES (all dimensions in metres)

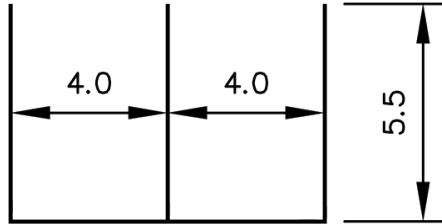

INDEPENDENT  
(STANDARD)

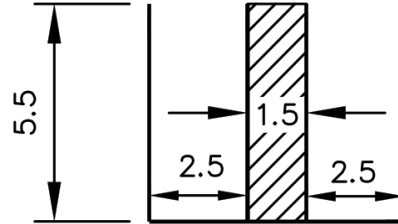

SHARED  
(ACCESSIBLE)

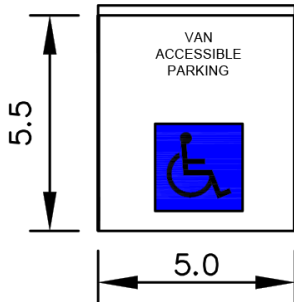

OR

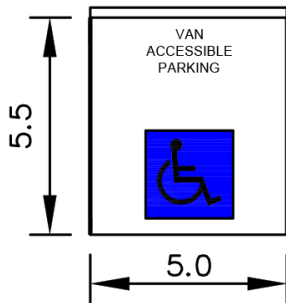
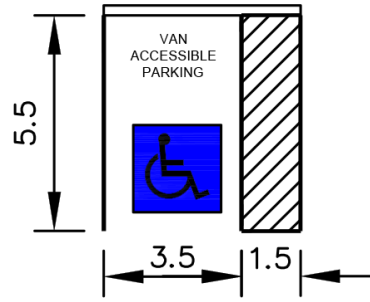

EQUIVALENT TO

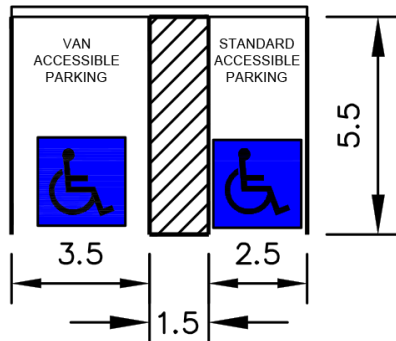
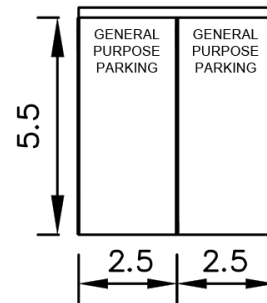

EQUIVALENT TO

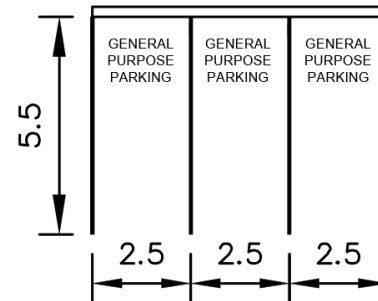

E/ LOADING SPACE (CLASS B) AND PASSENGER SPACE (CLASS B) (all dimensions in metres)

LOADING SPACE, CLASS B

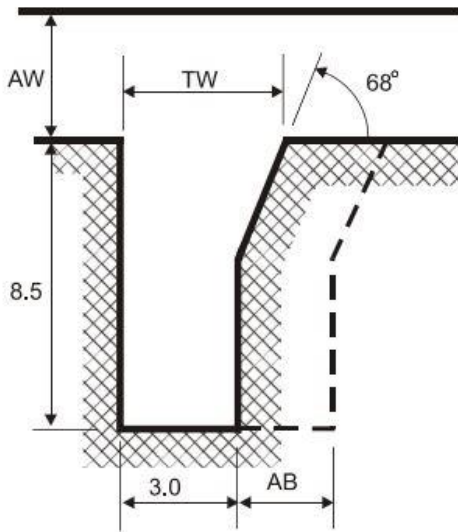

PASSENGER SPACE, CLASS B

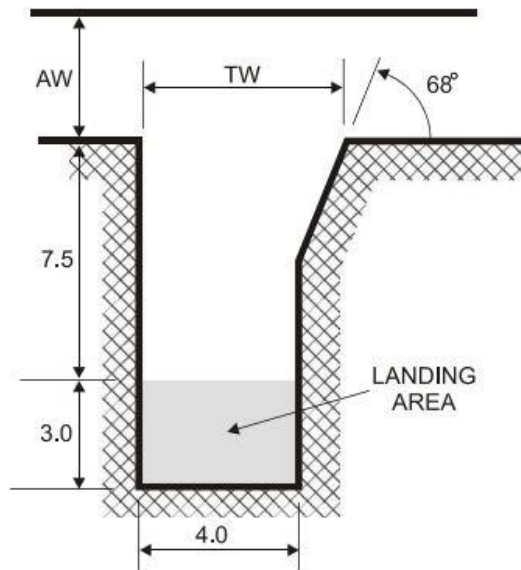

| CLASS B LOADING SPACE TABLE |                   |                           |
|-----------------------------|-------------------|---------------------------|
| AISLE WIDTH (AW)            | THROAT WIDTH (TW) | ADDITIONAL BAY WIDTH (AB) |
| 6.1                         | 4.6               | 3.8                       |
| 6.4                         | 4.4               | 3.7                       |
| 6.7                         | 4.1               | 3.5                       |
| 7.0                         | 4.0               | 3.4                       |
| 7.3                         | 3.8               | 3.2                       |
| 7.6                         | 3.7               | 3.0                       |
| 7.9                         | 3.5               | 3.0                       |
| 8.2                         | 3.3               | 3.0                       |
| 8.5                         | 3.0               | 3.0                       |

| PASSENGER SPACE TABLE* |                   |
|------------------------|-------------------|
| AISLE WIDTH (AW)       | THROAT WIDTH (TW) |
| 6.1                    | 4.6               |
| 6.4                    | 4.4               |
| 6.7                    | 4.1               |
| 7.0                    | 4.0               |
| 7.3                    | 4.0               |
| 7.6                    | 4.0               |

\* see Section III.B. regarding length for Class B spaces subsequent to first one required.